

Manzel® DSL Lubricators

Wide choice of standard modular components helps you meet application requirements more exactly without the added costs of a custom system.

DESCRIPTION

A basic pump-to-point system is shown in the illustration which depicts six pumps mounted on a common reservoir from which each pump is dispensing oil to a single lubrication point. These pumps are operated by individual cams on the drive shaft.

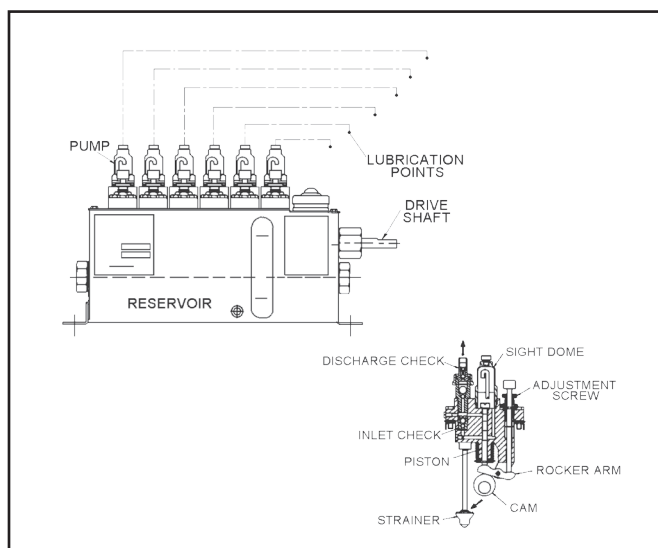

FEATURES / BENEFITS

- DSL Box Lubricators provide a proven, cost effective way to assemble customized oil systems that meet specific requirements by using standard modular components.
- DSL Box Lubricators increase opportunities to standardize lube system components and reduce lube maintenance and service costs.
- DSL Box Lubricators save you system design dollars and lead time.
- DSL Box Lubricators are dependable and backed by the industry's most comprehensive international distributor network-with application expertise, parts stocks and factory-trained service nearby, wherever you are located.

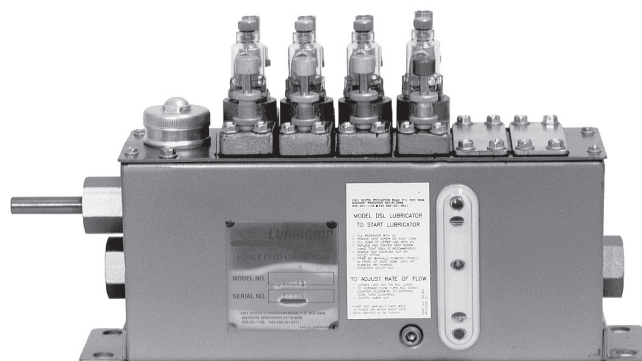
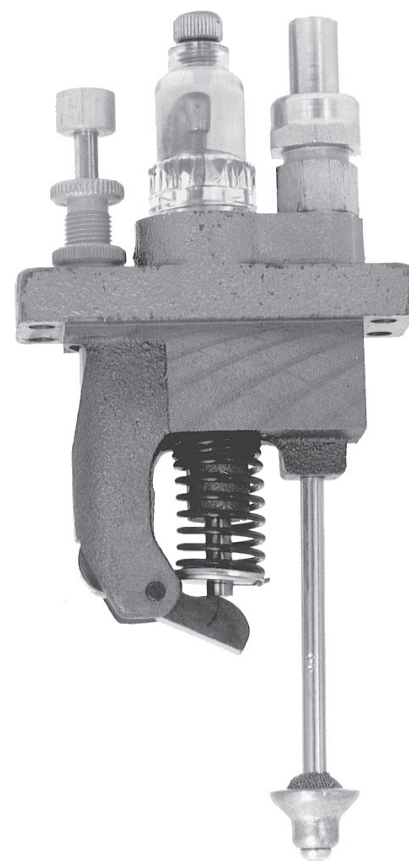

PUMPS

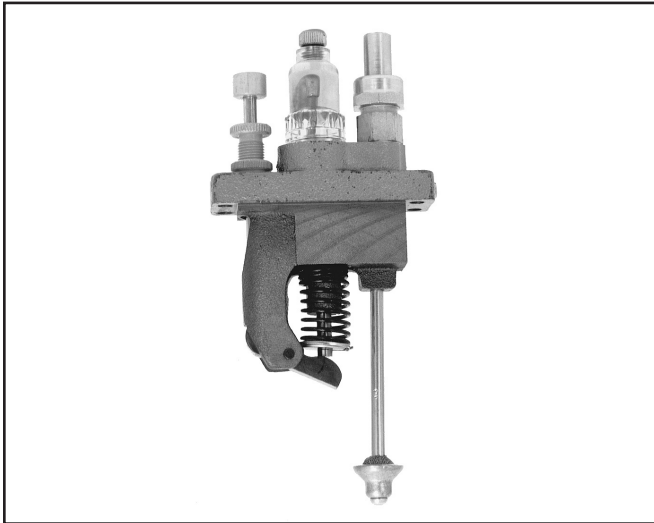

DESCRIPTION

DSL Box Lubricators feature heavy-duty precision metering pumps capable of accurately delivering small flows of either mineral or synthetic oil to machinery injection points. The single-piston pump is mechanically driven from a common camshaft in the reservoir and is adjustable from 2.0 to 6.25 drops per stroke. The 18 drive options provide many variations to suit the application.

The pump's maximum pressure is 3,000 psi. All working parts are totally enclosed away from dirt, water, and impurities and self-lubricated at all times by the fluid in the watertight reservoir.

DSL Pumps are rugged, heavy duty units. The pump cylinder housing is a precision machined casting fitted with an alloy steel piston.

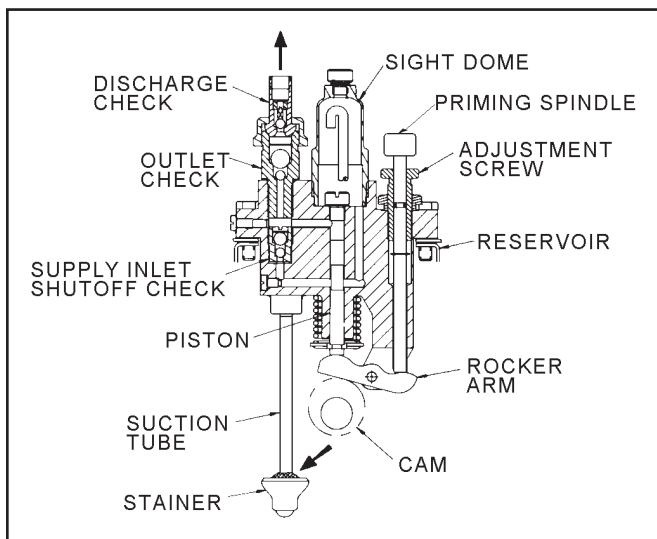

DSL PUMP W/SIGHT GLASS

FEATURES / BENEFITS

- Rugged construction for high performance and durability
- Easy serviceability-pumps can be added or replaced quickly
- Pump output is easily adjustable

OPERATION

Pumps With Drip Tube

Rotation of the lubricator cam actuates the pump rocker arm assembly to operate the pump piston. On the piston downstroke, spring pressure is exerted on the piston causing it to follow the cam. As it moves down, a pressure reduction (vacuum) is created between the piston and the outlet check valve and the valve closes. The supply inlet shutoff check is then unseated and lubricant is drawn into the piston cylinder from the sight well.

This creates a pressure reduction (vacuum) in the airtight sight well that causes lubricant from the reservoir to be drawn into the well until pressure is equalized. On the piston up-stroke, the oil in the cylinder is injected out through the discharge check valve to the machine injection point. The number of drops seen falling in the sight well is the amount of oil discharged by the pump. Each pump can be adjusted by means of an external screw. This changes the length of the piston down-stroke which changes the pump discharge volume. On up-stroke the piston always stops at the uppermost point, regardless of displacement adjustment.

Pumps With Pressurized Supplies

Rotation of the lubricator cam actuates the pump rocker arm assembly to operate the pump piston. On the piston downstroke, spring pressure is exerted on the piston causing it to follow the cam. As it moves down, a pressure reduction (vacuum) is created between the piston and the outlet check valve and the valve closes. This allows the pressurized supply to unseat the supply inlet shutoff check and fill the piston bore with lubricant. On the piston upstroke, the piston forces the supply inlet shutoff check to seat and shut off the pressurized supply. Lubricant in the piston cylinder is forced out through the discharge check valve to the machine injection point. Each pump can be adjusted by means of an external screw. This changes the length of the piston down-stroke which changes the pump discharge volume. On up-stroke the piston always stops at the uppermost point, regardless of displacement adjustment.

PUMP ADJUSTMENT

Pump discharge (output flow) can be adjusted within the min./ max. range as shown in the specifications. The adjustment is linear. Therefore, positioning the screw midway will produce one-half of the pump capacity. To adjust the flow, proceed as follows:

1. Loosen adjusting screw locknut.
2. Turn the adjusting screw to the desired position and, with the pump operating, count the drops falling in the sight well or rising in the sight feed for a one-minute interval.
3. Tighten adjusting screw locknut.

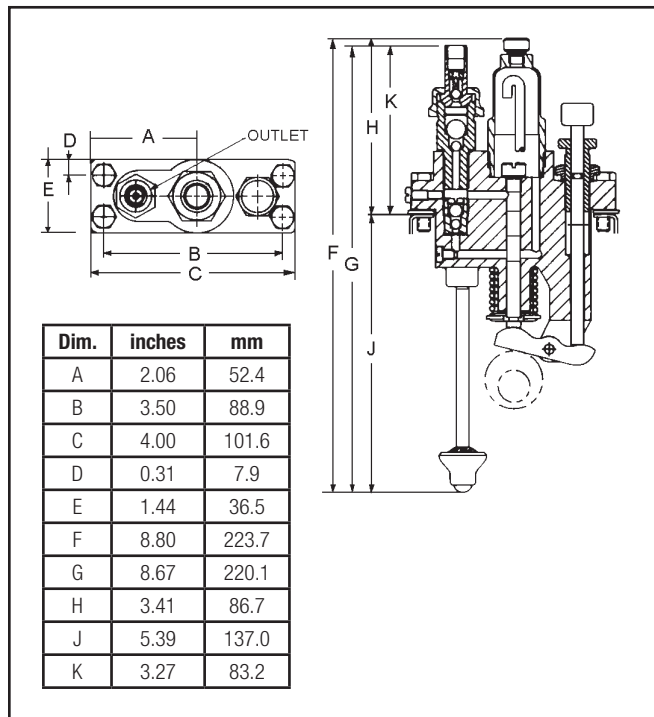

PUMP DIMENSIONS

RESERVOIRS

Five reservoir sizes are available for the DSL Lubricator. Each is ruggedly built to reduce deflection and provide longer life.

Camshaft intermediate support bearings are side mounted to reservoir to provide maximum rigidity without adding length.

Each reservoir is equipped to handle the maximum number of pumps. Unused pump stations include cams and are covered with a gasketed, blank cover assembly that can easily be removed to convert to an active pump station.

FEATURES / BENEFITS

- Rugged construction for durability
- Complete assembly - includes level sight gauge, fill cup and drain plug
- Precise camshaft alignment insures proper lubrication by all pumps
- Can be used in outdoor and ammonia (sour gas) environment

RESEVOIR DIMENSIONS					
CODE	PUMP	CAP'Y	"A"	"B"	"C"
R03	3	4 PINT	7.75	3.09	9.12
R06	6	8 PINT	12.75	3.25	14.12
R09	9	12 PINT	17.75	3.41	19.12
R12	12	16 PINT	22.75	3.56	24.12
R15	15	20 PINT	27.75	3.72	29.12

DRIVE OPTIONS

18 drive options are available from direct drive to a reduction ratio of 283:1. Options provide left- or right-hand end and front side/back side and bottom reservoir mounting.

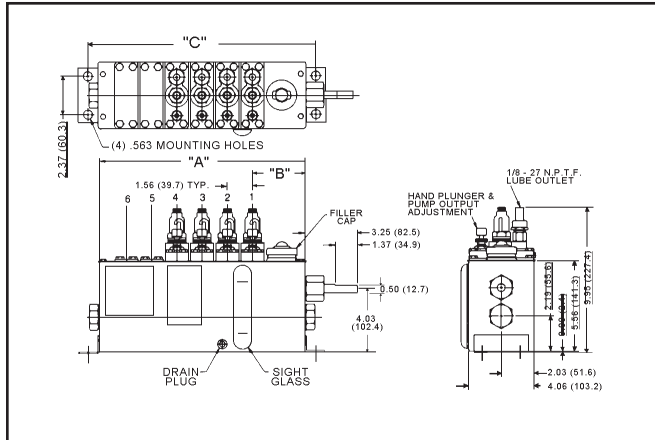

END ROTARY DRIVE

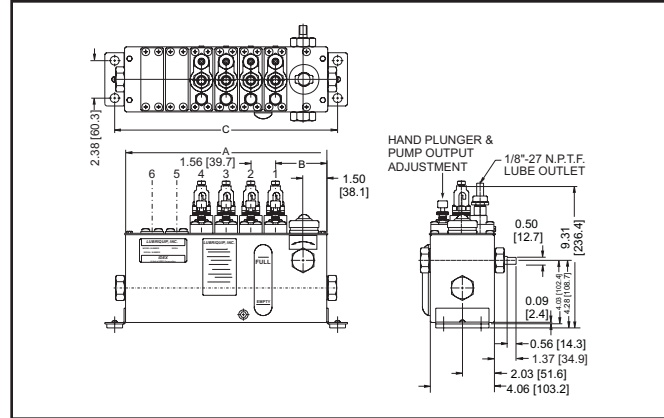

SIDE ROTARY DRIVE

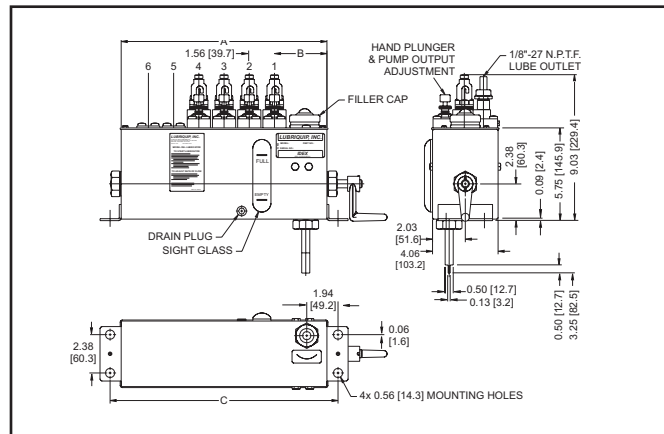

BOTTOM ROTARY DRIVE

ORDERING INFORMATION — For complete ordering information, please refer to the Industrial Lubrication Equipment Buyer's Guide on graco.com

Calculate Minimum or Maximum Pump Output Capacity

$$\frac{\text{Input Speed}}{\text{Gear Reduction}} \times (\text{min. or max. drops/stroke}^*) \times \frac{1440}{(\text{min./day})} = \text{Min. or Max. Pump Output (pints/day)}$$

14115 (number of drops in a pint)

*Minimum and maximum drops per stroke listed in the specification chart below.

Description	Part No.
(D1) 9/32 Vacuum Inlet Pump	256907
(D2) 9/32 Pressurized Inlet Pump (10 psi max)	256908
Vacuum Inlet Pump w/Suction Tube length reduced by 1 in.	256929

Ordering Code	Piston Size (Inches)	Maximum Pressure (Psi)	*Drops/Stroke		Cu.In/Stroke		Cm ³ /Stroke		Strokes/Min	
			Max	Min	Max	Min	Max	Min	Max	Min
D1	9/32	3000	6.25	2.0	0.15	.0048	.245	.079	25	3
D2	9/32	3000	6.25	2.0	.015	.0048	.245	.079	25	3

Contact us today!

To receive product information or speak with a Graco representative, call 800-533-9655 or visit us online at www.graco.com.

